

Address of Property: _____

EXHIBIT A.

APPLICANT'S ACKNOWLEDGEMENT FORM

I, _____, hereby acknowledge that I have on this day received this copy of the Town of Highland Park's ("Town's") prescribed methods for eliminating and/or reducing erosion nuisances. I understand this information, and I further understand that the Town will not tolerate erosion nuisances occurring on properties within the Town. I understand that I share with my fellow workers and others a duty to prevent erosion nuisances. And finally, I understand that the Town, pursuant to **Article 3.16 Erosion and Sedimentation Control** et seq., will promptly and thoroughly investigate all instances of erosion nuisances and will take remedial measures, up to and including issuing citations and a stop work order for that work on a property that necessarily involves land disturbing activities and which is causing, in whole or in part, an erosion nuisance(s).

APPLICANT:

WITNESS:

Signature

Signature

Date _____

Date _____

**TOWN OF HIGHLAND PARK'S PRESCRIBED METHODS OF
ELIMINATING AND/OR REDUCING EROSION NUISANCES**

- A. Limit the size of disturbed areas to the greatest extent possible.
- B. Provide and install silt fence and/or other control measures to intercept silt from disturbed areas.
- C. Keep the velocities of storm water runoff below the erosive level.
- D. Protect inlets, streets, alleys and waterways from surface runoffs.
- E. Minimize the extent of sediment leaving the project site.
- F. Revegetate all disturbed area with a rapid, vigorous growth of long-term vegetation as soon as possible.
- G. Reduce the silt leaving a construction site on the wheels of construction vehicles by providing vehicle washing areas and/or established construction entrances and exits.
- H. Preserve and protect existing vegetation to the greatest extent possible.
- I. All loose and excavated materials shall be removed at the end of each day from areas located within waterways and floodplains.
- J. Replace and/or repair erosion control measures that are in disrepair.

APPLICANT'S INITIALS: _____

EROSION/SEDIMENTATION CONTROL PLAN SUBMITTAL REQUIREMENTS

Sec. 3.16.011 Submission of Erosion/Sedimentation Control Plan to Town

(a) In instances where an Owner or an agent in charge of any property seeks to conduct and/or to perform work which will necessarily involve land disturbing activities including, but not limited to, excavation, grading, demolition, drainage work, and/or stock piling of unprotected soil(s) and sand(s) within the Town* (*as determined by the Town's Building Inspection Department), prior to the commencement of said work, the Owner or agent shall first submit to the Town Engineer for review an erosion and/or sedimentation control plan. The Town Engineer or his designee will review each proposed plan to determine its conformance with the provisions of the regulation. Within ten (10) business days after receiving a proposed plan, the Town Engineer shall, in writing:

- (1) Approve the proposed plan, and issue a permit for said work;
- (2) Approve the proposed plan subject to and under the reasonable conditions as may be necessary to secure substantially the objectives of this regulation, and issue the permit for said work subject to those conditions; or
- (3) Disapprove the proposed plan, with the reason(s) for same, and also include the necessary items, procedures and/or conditions for the applicant to cover and/or to satisfy in a revised, proposed plan.

(b) For (2) above, and where the Town Engineer conditions the approval of a proposed plan on the installation of certain sediment control devices, no grading or construction at or on the property shall begin until the approved sediment control devices are installed, inspected, and approved by the Town Engineer or his designee.

(c) The applicant shall conduct all land disturbing activities in strict accordance with the applicant's approved plan.

(d) By approval of the plan, should it in fact occur, neither the Town nor the Town Engineer stipulates or warrants that the proposed controls will be sufficient to prevent adverse impacts onto private or public properties. Accordingly, the Town shall not be deemed to waive, in whole or in part, its rights to pursue its legal remedies in order to prevent or to stop erosion nuisances, both under this ordinance, and all other applicable ordinances and laws.

This complete Article (Erosion/Sedimentation Control) and is available free to download from the Building Inspection Department webpage titled "Forms to Download" at www.hptx.org .

Contact: Heather Cerda, Project Coordinator – hcerda@hptx.org or 214-559-9358

SILT FENCE GENERAL NOTES:

1. POSTS WHICH SUPPORT THE SILT FENCE SHALL BE INSTALLED ON A SLIGHT ANGLE TOWARD THE ANTICIPATED RUNOFF SOURCE. POST MUST BE EMBEDDED A MINIMUM OF 1 FOOT. STEEL POSTS ARE REQUIRED WITH PLASTIC CAPS.
2. THE TOE OF THE SILT FENCE SHALL BE TRENCHED IN WITH A SPADE OR MECHANICAL TRENCHER, SO THAT THE DOWNSLOPE FACE OF THE TRENCH IS FLAT AND PERPENDICULAR TO THE LINE OF FLOW. WHERE FENCE CANNOT BE TRENCHED IN (E.G. PAVEMENT), WEIGHT FABRIC FLAP WITH ROCK ON UPHILL SIDE TO PREVENT FLOW FROM SEEPING UNDER FENCE.
3. THE TRENCH MUST BE A MINIMUM OF 6 INCHES DEEP AND 6 INCHES WIDE TO ALLOW FOR THE SILT FENCE FABRIC TO BE LAID IN THE GROUND AND BACKFILLED WITH COMPACTED MATERIAL.
4. SILT FENCE SHOULD BE SECURELY FASTENED TO EACH SUPPORT POST OR TO WIRE BACKING, WHICH IN TURN IS ATTACHED TO THE FENCE POST. THERE SHALL BE A 3 FOOT OVERLAP, SECURELY FASTENED WHERE ENDS OF FABRIC MEET.
5. INSPECTION SHALL BE AS SPECIFIED IN THE SWPPP. REPAIR OR REPLACEMENT SHALL BE MADE PROMPTLY AS NEEDED.
6. SILT FENCE SHALL BE REMOVED WHEN FINAL STABILIZATION IS ACHIEVED OR ANOTHER EROSION OR SEDIMENT CONTROL DEVICE IS EMPLOYED.
7. ACCUMULATED SILT SHALL BE REMOVED WHEN IT REACHES A DEPTH OF HALF THE HEIGHT OF THE FENCE. THE SILT SHALL BE DISPOSED OF AT AN APPROVED SITE AND IN SUCH A MANNER AS TO NOT CONTRIBUTE TO ADDITIONAL SILTATION.
8. SILT FENCE SHALL BE SET BACK A MINIMUM DISTANCE OF 18" FROM ALL TOWN SIDEWALKS AND 30" FROM PAVED ALLEY(S). NO SILT FENCE OR EROSION CONTROL DEVICE/SYSTEM SHALL BE INSTALLED IN AN EASEMENT, UNLESS PRIOR APPROVAL IS ISSUED FROM TOWN.
9. IN THE EVENT OF A STRUCTURE DEMOLITION/RAZE, A PRE-DEMO AND POST-DEMO EROSION CONTROL PLAN WILL BE REQUIRED PRIOR TO A DEMO PERMIT BEING ISSUED.

THE TOWN OF <i>Highland Park</i> TEXAS	STANDARD CONSTRUCTION DETAIL	DATE:
	SILT FENCE NOTES	FEB 2019
		SD-29B

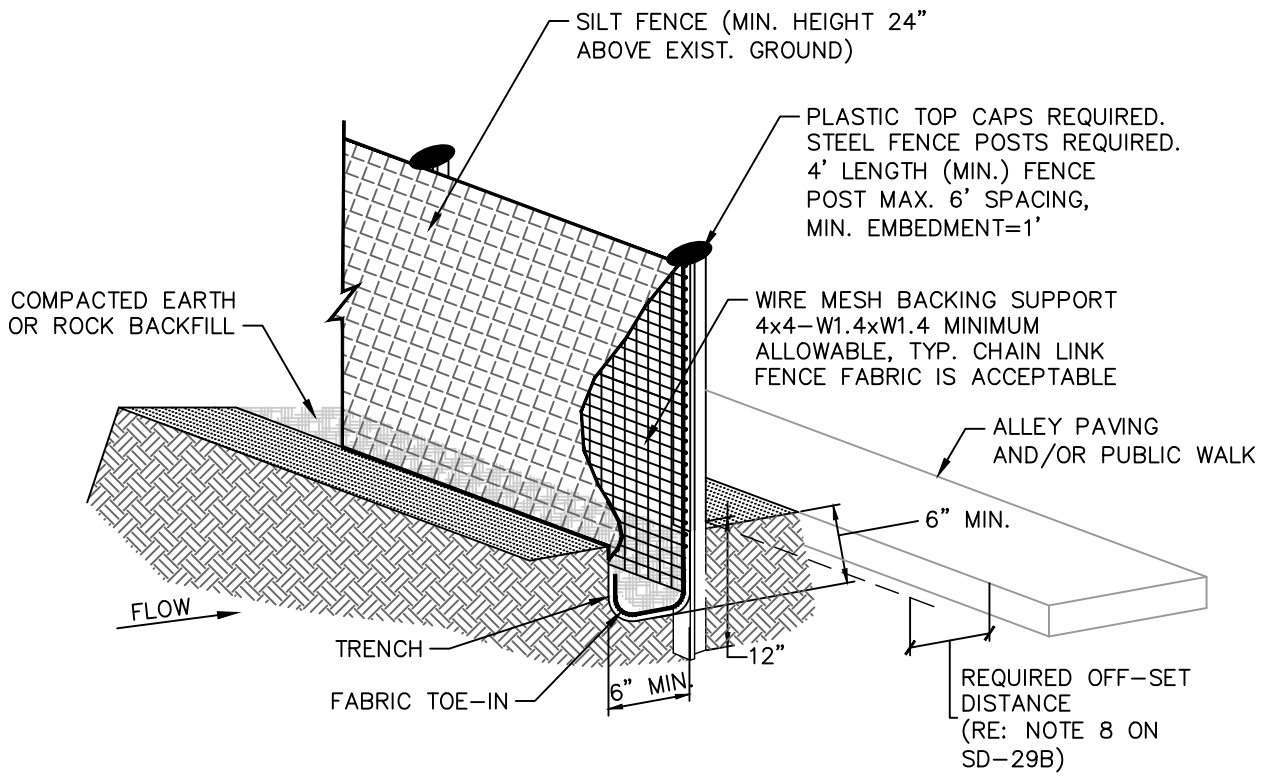

SILT FENCE

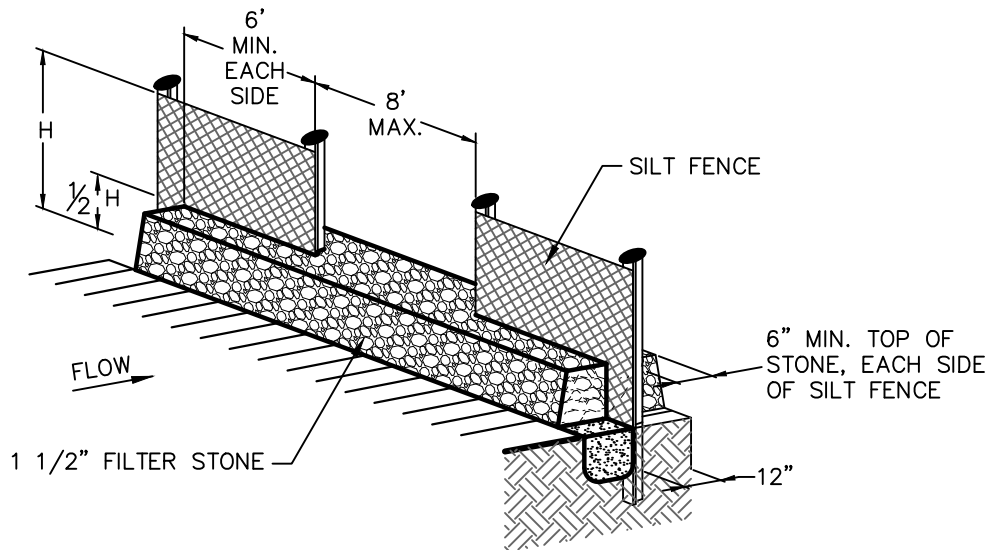

STONE OVERFLOW STRUCTURE

NOTE:

STONE OVERFLOW STRUCTURES OR OTHER OUTLET CONTROL DEVICES SHALL BE INSTALLED AT ALL LOW POINTS ALONG THE FENCE AT A MINIMUM OF EVERY 300 FEET.

THE TOWN OF <i>Highland Park</i> TEXAS	STANDARD CONSTRUCTION DETAIL	DATE:
	SILT FENCE	FEB 2019
		SD-29A

STABILIZED CONSTRUCTION ENTRANCE GENERAL NOTES:

1. STONE SHALL BE 3 TO 5 INCH DIAMETER COARSE AGGREGATE.
2. THE THICKNESS SHALL NOT BE LESS THAN 12 INCHES.
3. THE WIDTH SHALL BE NO LESS THAN THE FULL WIDTH OF ALL POINTS OF INGRESS OR EGRESS, 30' (MIN).
4. WHEN NECESSARY, VEHICLES SHALL BE CLEANED TO REMOVE SEDIMENT PRIOR TO ENTRANCE ONTO A PUBLIC ROADWAY. WHEN WASHING IS REQUIRED, IT SHALL BE DONE ON AN AREA STABILIZED WITH CRUSHED STONE WITH DRAINAGE FLOWING AWAY FROM BOTH THE STREET AND THE STABILIZED ENTRANCE. ALL SEDIMENT SHALL BE PREVENTED FROM ENTERING ANY STORM DRAIN, DITCH OR WATERCOURSE USING APPROVED METHODS.
5. THE ENTRANCE SHALL BE MAINTAINED IN A CONDITION WHICH WILL PREVENT TRACKING OR FLOWING OF SEDIMENT ONTO PAVED SURFACES. THIS MAY REQUIRE PERIODIC TOP DRESSING WITH ADDITIONAL STONE AS CONDITIONS DEMAND. ALL SEDIMENT SPILLED, DROPPED, WASHED, OR TRACKED ONTO PAVED SURFACES MUST BE REMOVED IMMEDIATELY.
6. THE ENTRANCE MUST BE PROPERLY GRADED OR INCORPORATE A DRAINAGE SWALE TO PREVENT RUNOFF FROM LEAVING THE CONSTRUCTION SITE.
7. PREVENT SHORTCUTTING OF THE FULL LENGTH OF THE CONSTRUCTION ENTRANCE BY INSTALLING BARRIERS AS NECESSARY.
8. INSPECTION SHALL BE AS SPECIFIED IN THE SWPPP.

THE TOWN OF <i>Highland Park</i> TEXAS	STANDARD CONSTRUCTION DETAIL	DATE:
	STABILIZED CONSTRUCTION ENTRANCE NOTES	FEB 2019
		SD-28B

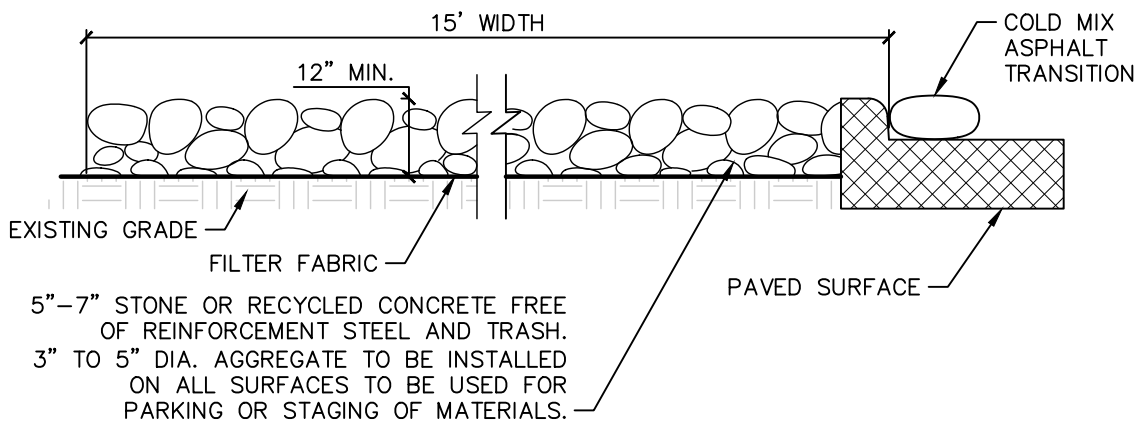
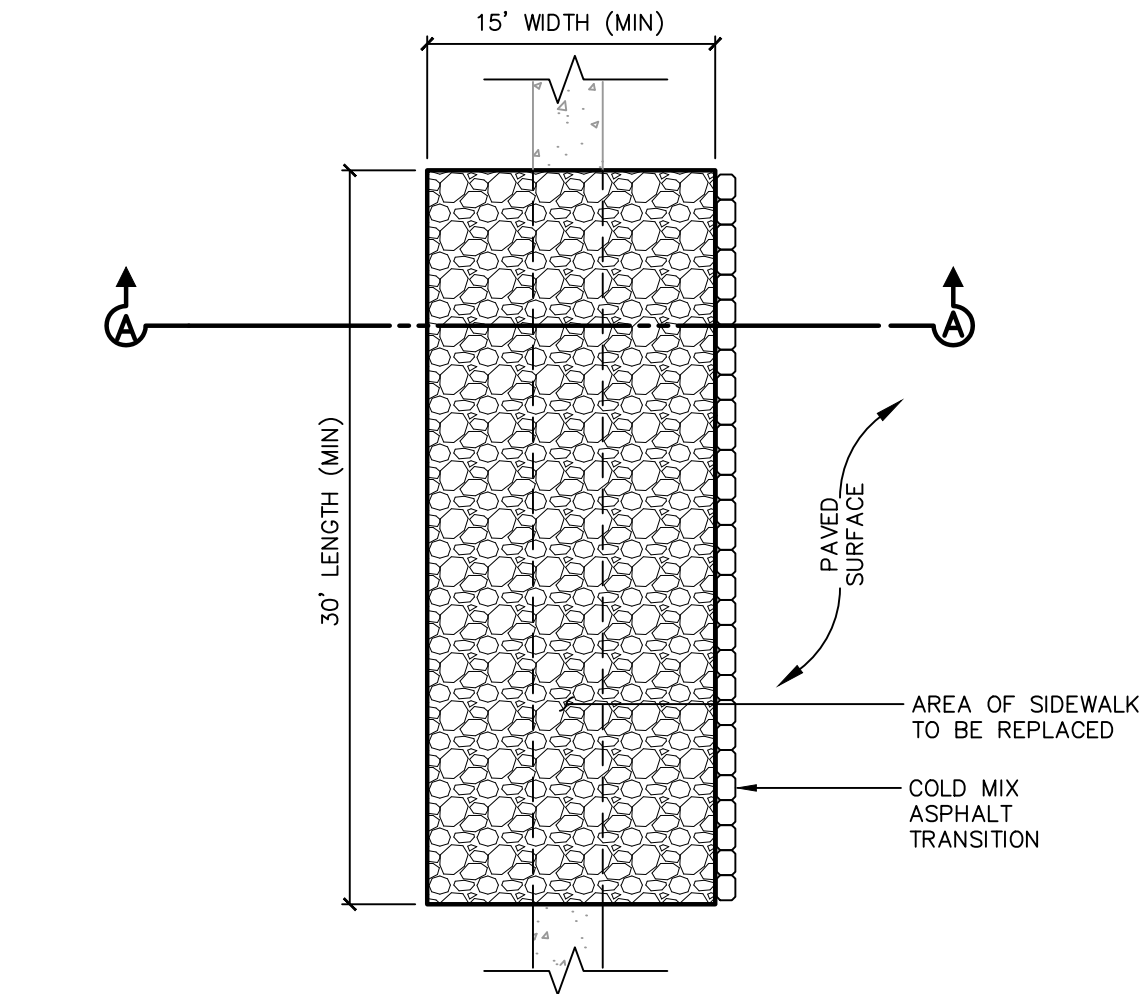

SECTION A-A

NOTES

1. INSTALL SILT FENCE, CONSTRUCTION SAFETY FENCING OR SIMILAR BARRIER ALONG THE EXIT TO DIRECT TRAFFIC INTO THE EXIT.
2. GRADE TO DRAIN AWAY FROM STABILIZATION, PAVED SURFACES, AND TO PREVENT RUNOFF FROM LEAVING THE SITE.
3. ANY EXISTING SIDEWALK AND CURB WITHIN THE LIMITS OF THE CONSTRUCTION ENTRANCE SHALL BE REPLACED.

<p>THE TOWN OF</p> 	STANDARD CONSTRUCTION DETAIL	DATE:
	STABILIZED CONSTRUCTION ENTRANCE	FEB 2019
		SD-28A